

Advantages

Constant Flow - Depending on peak business requirements, marketers now have a choice of either 2 hp or 4 hp variable speed models. 2 hp provides constant 10 gpm (38 lpm) for up to eight fueling positions operating simultaneously, 4 hp for up to 12 positions.

MagVFC™ Design Highlights -

The MagVFC™ features a dual seven segment display to show diagnostic faults. A serial interface is standard to connect to INCON System Sentinel™ software for remote reporting of pump alarms and sharing other pump/ATG intelligence. The MagVFC™ detects and displays these system conditions:

- Dry tank (initiates an immediate pump shutdown).
- Continuous pump run.
- Low incoming voltage.
- Pump motor failure.
- Short circuit detection.
- Controller faults.
- Open circuit detection.

For reduced installation cost, a shielded power cable is not required. Pump protection extends pump life and extended run fault alerts a condition that may render line leak detection ineffective. Remote reporting of pump alarms and sharing of IST and ATG intelligence further reduce station operating costs.

Meets EPA Spitback Control -

The IST can be adjusted at installation to perform at maximum per nozzle flow rate of 10 gpm (38 lpm) based on the specifications of your piping and dispensing system. This eliminates overpressuring the system, which results in an unnecessarily high hydraulic hammer and need for other control devices.

Intelligent Submersible Turbine Pumps

FE Petro introduced the first variable speed submersible pump for the petroleum industry in 1995. Since that time, high volume marketers around the world have realized the benefits of filling cars faster during peak business periods that only variable speed submersibles can deliver. Station size and volumes have continued to grow. To meet the needs of these high volume retailers, FE Petro offers the intelligent submersible turbine pump, the industry's highest performing 4" diameter submersible pump.



Constant Flow



Spitback Control



MagVFC™

Intelligent Submersible Turbine Pump Specifications

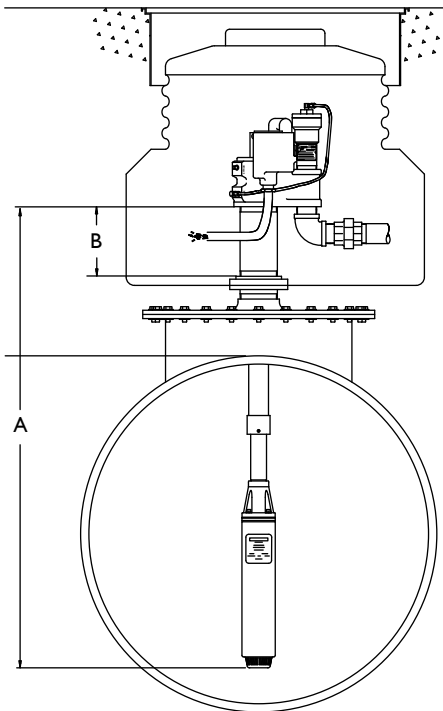

For full diagram see page 5.

Power Requirements

IST models can only be powered by a MagVFC™ controller:

- 2 hp models can operate with single- or three-phase incoming power supply to the MagVFC™.
- 4 hp models require three-phase incoming power supply to the MagVFC™ for proper operation.
- Incoming power supply to the MagVFC™ can be 200-250 VAC, 50 or 60 Hz.
- MagVFC™ outputs a three-phase, variable frequency signal, valid for FE Petro variable speed pumps only.
- 2 hp max. motor draw: 9 Amps.
- 4 hp max. motor draw: 15 Amps.
- MagVFC™ max. line draw: 20 Amps.

Pump Motor

- 2 hp or 4 hp, variable speed, two-stage centrifugal type pump motor with integral, automatic, thermal overload protection.
- Max. flow: 2 hp = 110 gpm, 4 hp = 140 gpm.
- Max. pressure: selectable operating pressure on MagVFC™ between 24 psi and 42 psi deadhead.
- Available with MagShell™, which results in 45% increased flow area around motor.

Liquid Compatibility

- Max. liquid viscosity: 70 SSU at 60 °F (15 °C).
- IST models imply alcohol-gasoline compatibility for fuel mixtures containing up to 100% ethanol or methanol, and 20% MTBE, 20% ETBE or 17% TAME with gasoline.
- IST models can also be used with diesel fuels, fuel oils, kerosene, Avgas and jet fuels in a non-gelled pourable state.
- All wetted elastomers are made of a high grade, fluorocarbon Viton® compound.

Standard Features

- All IST models include variable speed, variable length options and alcohol-gasoline compatibility.
- Check valve: 2-3/4" diameter fluorocarbon Viton® seal constructed on cast aluminum body and steel backing washer.
- Pressure relief valve: available in four pressure relief settings, integral to check valve. Standard model relieves at 40 psi and resets above 35 psi.
- Syphon: venturi-type syphon primer supplied with every submersible. Syphon check valve and secondary syphon sold separately.
- Air eliminator: every submersible includes tank return path with one-way check valve to provide active air elimination.
- Electrical disconnect: electrical yoke for positive contractor disconnect during service.

Approvals

- Consult factory for applicable approvals.

Quality Certification

- Franklin Fueling Systems is an ISO 9001 Certified Manufacturer.
- *Viton® is a registered trademark of DuPont Dow Elastomers.



Intelligent Submersible Turbine Pump Model Designation System

A typical turbine model designation has up to five components to define the pump being supplied as follows:

IST XXXXX Y - A - B

IST = Basic Model Designation

Note: All IST models include the options of alcohol-gasoline compatibility, variable speed and variable length as part of the base model.

XXXXX = Factory Installed Options

IST model designations may include one or more of the following characters in alphabetical order:

F = Floating suction adapter (1-1/2" NPT female adapter)

K = Intake filter screen (IFS, factory installed to PMA)

M = MagShell™ (flow enhancing, expanded PMA shell)

R* = Model R check valve (24 psi relief/22 psi reset for PLLD)

W* = Model W check valve (16 psi relief/13 psi reset for PPM4000)

*Note: If not otherwise specified, all IST models are supplied with standard model check valve (40 psi relief/35 psi reset for MLD and TS-LS300).

Y = Pump Motor Horsepower Rating**

VS4 = 4 hp variable speed

**Note: If not otherwise specified, 2 hp variable speed is implied.

A = Model Length

1 = 2 hp variable length, 59"-87"

2 = 2 hp variable length, 90"-151"

3 = 2 hp variable length, 122"-213"

VL1 = 4 hp variable length, 64"-92"

VL2 = 4 hp variable length, 95"-156"

VL3 = 4 hp variable length, 127"-218"

Note: IST-2 and ISTVS4-VL2 models fit 94% of all known installations.

B = Riser Pipe Length

Riser pipe length is expressed as two numeric characters that indicate the total length of the riser in inches. Riser pipes are available from 7" to 69" in 1" increments (additional charge for risers 31" or longer).

Intelligent Submersible Turbine Pumps (variable speed, variable length, AG compatible)

Model	Description	Model Length* Range
ISTM-1	2 hp variable speed with MagShell™	59"-87"
ISTM-2	2 hp variable speed with MagShell™	90"-151"
ISTM-3	2 hp variable speed with MagShell™	122"-213"
ISTMVS4-VL1	4 hp variable speed with MagShell™	64"-92"
ISTMVS4-VL2	4 hp variable speed with MagShell™	95"-156"
ISTMVS4-VL3	4 hp variable speed with MagShell™	127"-218"

- Notes:
1. Remove "M" from model number for non-MagShell™ pump motor assembly.
 2. All above models are compatible with fuel mixtures containing up to 100% ethanol or methanol with gasoline, diesel fuels, and 20% MTBE, 20% ETBE or 17% TAME with gasoline.
 3. All models are supplied with a standard check valve unless factory option "R" or "W" is specified.
 4. All above models can only be powered by a MagVFC™. 4 hp models require three-phase incoming power supply, 2 hp models can be supplied with single- or three-phase incoming power.
 5. 4" riser pipe, if supplied locally, must be 4-1/2" OD by 3/16" WT tubing.
 6. For riser pipe lengths 31" to 69", adder charge applies.

*Model length (A) defined as the dimension from turbine manifold bottom to pump motor inlet.

Factory Installed Options (specified in model number at time of IST order)

Designation	Description
F	Floating suction adapter, 1-1/2" NPT female, must be factory installed
K	IFS (intake filter screen) factory assembled to pump motor assembly
R	Model R check valve, factory installed, for Veeder-Root PLLD Line Leak
W	Model W check valve, factory installed, for Red Jacket PPM4000 Line Leak

Field Installed Options (intelligent submersible turbine pump specific accessories)

Part Number	Description
5874202800	MagVFC™, 2 hp or 4 hp variable frequency controller, one required per IST
400137908	Syphon check valve, alcohol-gasoline compatible (when ordered with IST)
402459931	Model 65 psi check valve (for slave of manifolded ISTs with Veeder-Root PLLD)
402507930	Secondary syphon kit (when two syphon primes are required for one IST)

Variable Speed Conversion Kits (AG compatible)

Part Number	Description
400693905	Kit with AG compatible 2 hp variable speed non-MagShell™ (PMAAGVS2)
400693906	Kit with AG compatible 2 hp variable speed with MagShell™ (PMAAGMVS2)
402671905	Kit with AG compatible 4 hp variable speed non-MagShell™ (PMAAGVS4)
402671906	Kit with AG compatible 4 hp variable speed with MagShell™ (PMAAGMVS4)

Note: Kits include variable speed pump motor assembly, MagVFC™ variable frequency controller, four-wire contractor's plug and installation instructions.

Variable Speed Submersible Turbine Pump Specifications

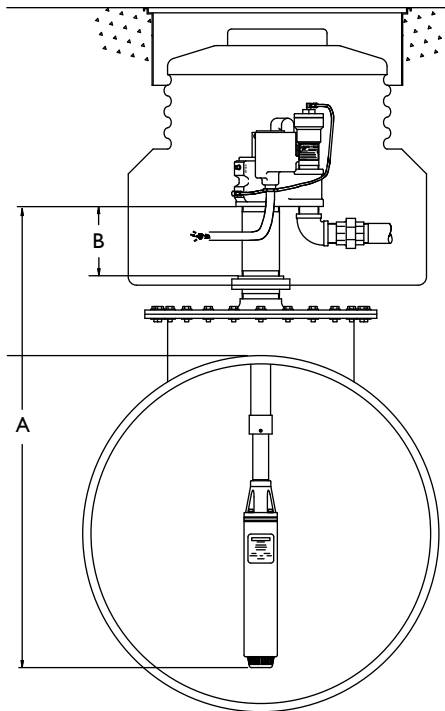

For full diagram see page 5.

Power Requirements

VS models can only be powered by a MagVFC™ controller:

- VS2 models can operate with single- or three-phase incoming power supply to the MagVFC™.
- VS4 models require three-phase incoming power supply to the MagVFC™ for proper operation.
- Incoming power supply to the MagVFC™ can be 200-250 VAC, 50 or 60 Hz.
- MagVFC™ outputs a three-phase, variable frequency signal, valid for FE Petro variable speed pumps only.
- VS2 max. motor draw: 9 Amps.
- VS4 max. motor draw: 15 Amps.
- MagVFC™ max. line draw: 20 Amps.

Pump Motor

- 2 hp or 4 hp, variable speed, two-stage centrifugal type pump motor with integral, automatic, thermal overload protection.
- Max. flow: VS2 = 110 gpm, VS4 = 140 gpm.
- Max. pressure: selectable operating pressure on MagVFC™ between 24 psi and 42 psi deadhead.
- Available with MagShell™ which results in 45% increased flow area around motor.

Liquid Compatibility

- Max. liquid viscosity: 70 SSU at 60 °F (15 °C).
- Variable speed models are UL and cUL listed for fuel mixtures containing up to 15% ethanol or methanol, and 20% MTBE, 20% ETBE or 17% TAME with gasoline.
- Variable speed (non-AG) models can also be used with diesel fuels, fuel oils, kerosene, Avgas and jet fuels in a non-gelled pourable state.
- All wetted elastomers are made of a high grade, fluorocarbon Viton® compound.

Standard Features

- Variable speed models are available in variable and fixed length options.
- Check valve: 2-3/4" diameter fluorocarbon Viton® seal constructed on cast aluminum body and steel backing washer.
- Pressure relief valve: available in four pressure relief settings, integral to check valve. Standard model relieves at 40 psi and resets above 35 psi.
- Syphon: venturi-type syphon primer supplied with every submersible. Syphon check valve and secondary syphon sold separately.
- Air eliminator: every submersible includes a tank return path with one-way check valve to provide active air elimination.
- Electrical disconnect: electrical yoke for positive contractor disconnect during service.

Approvals

- Consult factory for applicable approvals.

Quality Certification

- Franklin Fueling Systems is an ISO 9001 Certified Manufacturer.

*Viton® is a registered trademark of DuPont Dow Elastomers.



Variable Speed Submersible Turbine Pump Model Designation System

A typical turbine model designation has up to five components to define the pump being supplied as follows:

STP XXXXX Y - A - B

STP = Basic Model Designation

Note: All STP models include alcohol-gasoline compatibility, variable speed and variable length as part of the base model.

XXXXX = Factory Installed Options

STP model designations may include one or more of the following characters in alphabetical order:

F = Floating suction adapter (1-1/2" NPT female adapter)

K = Intake filter screen (IFS, factory installed to PMA)

M = MagShell™ (flow enhancing, expanded PMA shell)

*R = Model R check valve (24 psi relief/22 psi reset for PLLD)

*W = Model W check valve (16 psi relief/13 psi reset for PPM4000)

*Note: If not otherwise specified, all STP models are supplied with standard model check valve (40 psi relief/35 psi reset for MLD and TS-LS300).

Y = Pump Motor Horsepower Rating

VS2 = 2 hp variable speed

VS4 = 4 hp variable speed

A = Model Length

VL1 = Variable length range #1.

VL2 = Variable length range #2.

VL3 = Variable length range #3.

Note: VL2 models fit 94% of all known installations.

B = Riser Pipe Length

Riser pipe length is expressed as two numeric characters that indicate the total length of the riser in inches. Riser pipes are available from 7" to 69" in 1" increments (additional charge for risers 31" or longer).

2 HP Variable Speed Turbine Performance Chart

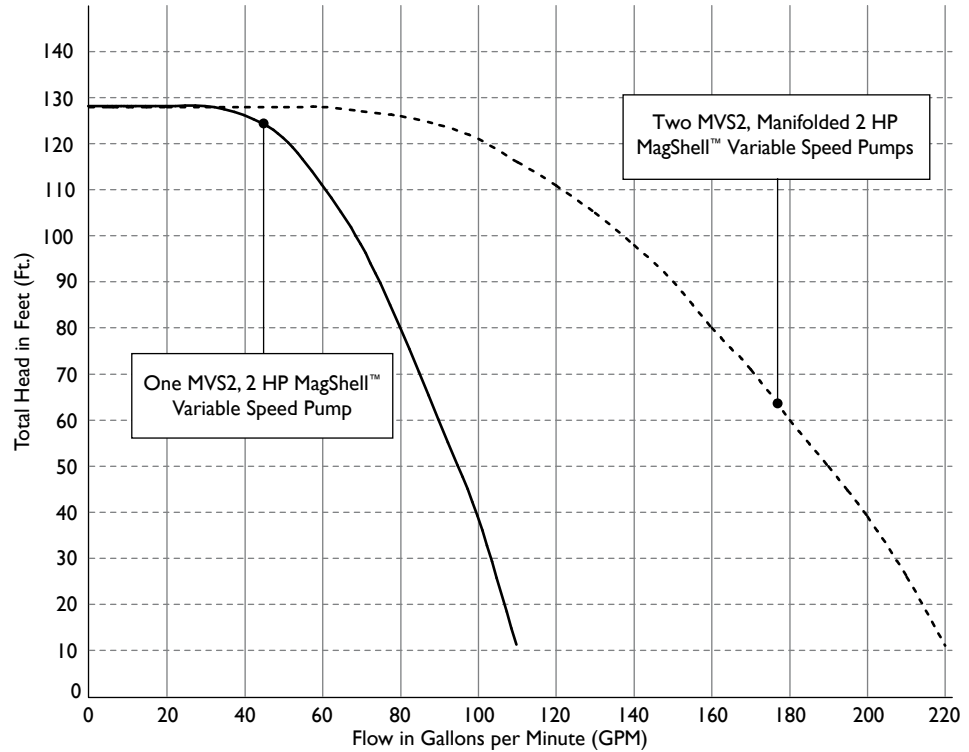

Note: Performance based on pumping gasoline (0.76 specific gravity). Pressure is taken at the manifold discharge outlet. ISTMV2 and STPMV2 turbines can only be powered by a MagVFC™ with single- or three-phase incoming power.

4 HP Variable Speed Turbine Performance Chart

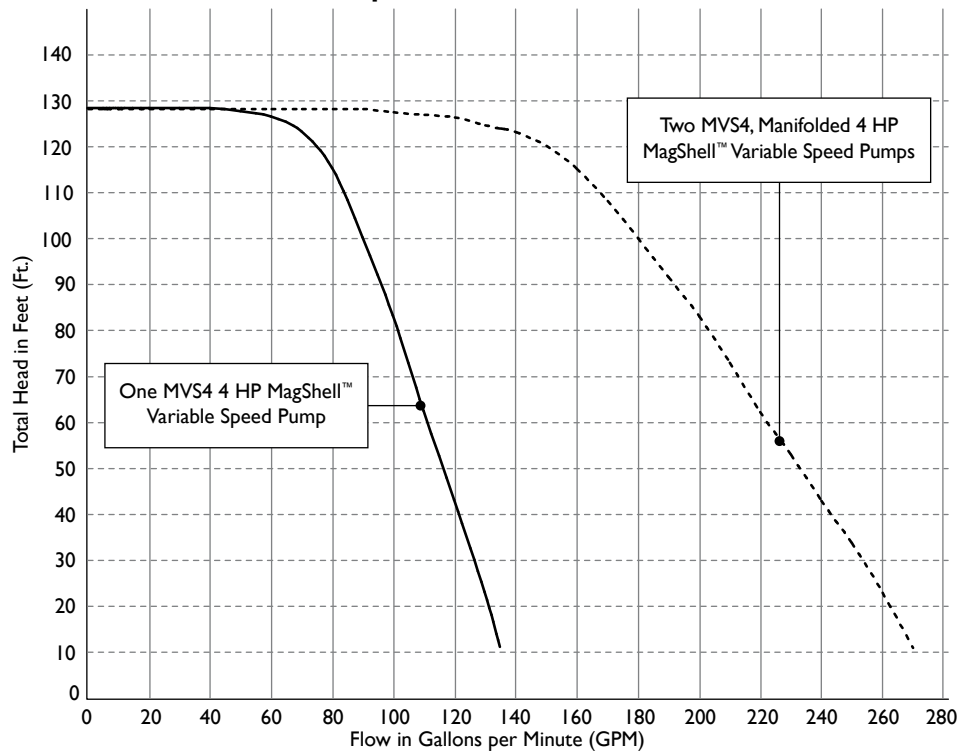

Note: Performance based on pumping gasoline (0.76 specific gravity). Pressure is taken at the manifold discharge outlet. ISTMV4 and STPMV4 turbines can only be powered by a MagVFC™ with three-phase incoming power.

Variable Speed Submersible Turbine Pumps (variable speed, variable length)

Model	Description	Model Length Range Number	Model Length* Range
STPMVS2-VL1	2 hp variable speed with MagShell™	VL1	59"-87"
STPMVS2-VL2	2 hp variable speed with MagShell™	VL2	90"-151"
STPMVS2-VL3	2 hp variable speed with MagShell™	VL3	122"-213"
STPMVS4-VL1	4 hp variable speed with MagShell™	VL1	64"-92"
STPMVS4-VL2	4 hp variable speed with MagShell™	VL2	95"-156"
STPMVS4-VL3	4 hp variable speed with MagShell™	VL3	127"-218"

- Notes:
1. Remove "M" from model number for non-MagShell™ pump motor assembly.
 2. All above models are UL and cUL listed for compatibility with fuel mixtures containing up to 15% ethanol or methanol with gasoline, diesel fuels, and 20% MTBE, 20% ETBE or 17% TAME with gasoline.
 3. All models are supplied with a standard check valve unless factory option "R" or "W" is specified.
 4. All above models can only be powered by a MagVFC™. 4 hp models require three-phase incoming power supply, 2 hp models can be supplied with single- or three-phase incoming power.
 5. 4" riser pipe, if supplied locally, must be 4-1/2" OD by 3/16" WT tubing.
 6. For riser pipe lengths 31" to 69", adder charge applies.

*Model length (A) defined as the dimension from turbine manifold bottom to pump motor inlet.

Factory Installed Options (specified in model number at time of STP order)

Designation	Description
F	Floating suction adapter, 1-1/2" NPT female, must be factory installed
K	IFS (intake filter screen) factory assembled to pump motor assembly
R	Model R check valve, factory installed, for Veeder-Root PLLD Line Leak
W	Model W check valve, factory installed, for Red Jacket PPM4000 Line Leak

Field Installed Options (intelligent submersible turbine pump specific accessories)

Part Number	Description
5874202800	MagVFC™, 2 hp or 4 hp variable frequency controller, one required per IST
400137908	Syphon check valve, alcohol-gasoline compatible (when ordered with IST)
402459931	Model 65 psi check valve (for slave of manifolded ISTs with Veeder-Root PLLD)
402507930	Secondary syphon kit (when two syphon primes are required for one IST)

Variable Speed Conversion Kits

Part Number	Description
402671901	Kit with 4 hp variable speed non-MagShell™ (PMA VS4)
400693901	Kit with 2 hp variable speed non-MagShell™ (PMA VS2)

Note: Kits include variable speed pump motor assembly, MagVFC™ variable frequency controller, four-wire contractor's plug and installation instructions.