

Fixed Length Submersible Turbine Pump Specifications

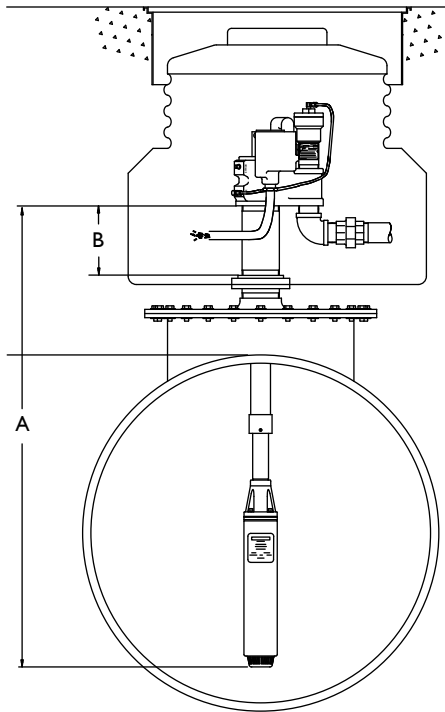

For full diagram see page 5.

Power Requirements

- Fixed length, fixed speed models require single-phase, 208-230 VAC, 60 Hz incoming power.
- Fixed length, fixed speed models are available in 1/3, 3/4, 1-1/2 and 2 hp versions.
- Fixed length, fixed speed models incorporate a starting and running capacitor with internal bleed resistor.
- A 370 Volt, 15 microfarad rated capacitor is used with 1/3, 3/4 and 1-1/2 hp fixed length, fixed speed versions.
- A 370 Volt, 40 microfarad rated capacitor is used with 2 hp fixed length, fixed speed versions.
- STP-SCI single-phase smart controllers and STP-CBS single-phase control boxes are available for fixed speed pump control.

Pump Motor

- Fixed speed, 3450 rpm, multi-stage centrifugal type pump motor with integral, automatic, thermal overload protection.
- 1/3 and 3/4 hp fixed speed models are available as two-stage versions.
- 1-1/2 and 2 hp fixed speed models are available in standard pressure (two-stage) versions and high pressure (H option, three-stage) versions.

Liquid Compatibility

- Max. liquid viscosity: 70 SSU at 60 °F (15 °C).
- Fixed length STP models are UL and cUL listed for fuel mixtures containing up to 15% ethanol or methanol, and 20% MTBE, 20% ETBE or 17% TAME with gasoline.
- AG (alcohol-gasoline) models are compatible with fuel mixtures containing up to 100% ethanol or methanol, and 20% MTBE, 20% ETBE or 17% TAME with gasoline.
- Fixed length models can also be used with diesel fuels, fuel oils, kerosene, Avgas and jet fuels in a non-gelled pourable state.
- All wetted elastomers are made of a high grade, fluorocarbon Viton® compound.

Standard Features

- Check valve: 2-3/4" diameter fluorocarbon Viton® seal constructed on cast aluminum body and steel backing washer.
- Pressure relief valve: available in four pressure relief settings, integral to check valve. Standard model relieves at 40 psi and resets above 35 psi.
- Syphon: venturi-type syphon primer supplied with every submersible. Syphon check valve and secondary syphon sold separately.
- Air eliminator: every submersible includes a tank return path with one-way check valve to provide active air elimination.
- Electrical disconnect: electrical yoke for positive contractor disconnect during service.

Approvals

- Consult factory for applicable approvals.

Quality Certification

- Franklin Fueling Systems is an ISO 9001 Certified Manufacturer.

*Viton® is a registered trademark of DuPont Dow Elastomers.



Fixed Length Submersible Turbine Pump Model Designation System

A typical turbine model designation has up to five components to define the pump being supplied as follows:

STP XXXXX Y - A - B

STP = Basic Model Designation

XXXXX = Factory Installed Options

STP model designations may include one or more of the following characters in alphabetical order:

AG = Alcohol-gasoline compatible (100% ethanol or methanol capable)
Note: Standard models 0% to 15% ethanol or methanol capable.

F = Floating suction adapter (1-1/2" NPT female adapter)

H = High pressure (1-1/2 hp and 2 hp models only)

K = Intake filter screen (IFS, factory installed to PMA)

M = MagShell™ (2 hp models only)

*R = Model R check valve (24 psi relief/22 psi reset for PLLD)

*W = Model W check valve (16 psi relief/13 psi reset for PPM4000)

*Note: If not otherwise specified, all STP models supplied with standard model check valve (40 psi relief/35 psi reset for MLD and TS-LS300).

Y = Pump Motor Horsepower Rating

33 = 1/3 hp fixed speed

75 = 3/4 hp fixed speed

150 = 1-1/2 hp fixed speed

200 = 2 hp fixed speed

A = Model Length

Model length is expressed as three numeric characters that indicate the length of the STP from the turbine manifold bottom to the pump motor inlet in inches, available from 37" to 211" (additional charge for models 133" and longer).

B = Riser Pipe Length

Riser pipe length is expressed as two numeric characters that indicate the total length of the riser in inches. Riser pipes are available from 7" to 69" in 1" increments (additional charge for risers 31" or longer).

Fixed Length Submersible Turbine Pumps

Model	Description	Model Length* Range
STP33	1/3 hp fixed speed	37"-132"
STP75	3/4 hp fixed speed	37"-132"
STP150	1-1/2 hp fixed speed	37"-132"
STPH150	1-1/2 hp high pressure fixed speed	37"-132"
STPM200	2 hp fixed speed with MagShell™	37"-132"
STPHM200	2 hp high pressure fixed speed with MagShell™	37"-132"

- Notes:
1. Remove "M" from model number for non-MagShell™ pump motor assembly.
 2. STP models are compatible with fuel mixtures containing: up to 15% ethanol or methanol with gasoline, and 20% MTBE, 20% ETBE or 17% TAME with gasoline.
STPAG models are compatible with fuel mixtures containing: up to 100% ethanol or methanol with gasoline, and 20% MTBE, 20% ETBE or 17% TAME with gasoline.
 3. All models are supplied with a standard check valve unless factory option "R" or "W" is specified.
 4. All above models require single-phase, 208-230 VAC, 60 Hz incoming power.
 5. 4" riser pipe, if supplied locally, must be 4-1/2" OD by 3/16" WT tubing.
 6. For riser pipe lengths 31" to 69", adder charge applies.

*Model length (A) defined as the dimension from turbine manifold bottom to pump motor inlet. Model length (A) can be a minimum of 37" to a maximum of 211". Adder charge applies if model length (A) is 133" to 180" (charge is for boards to protect STP shipment). Adder charge applies if model length (A) is 181" to 211" (charge is for crating STP).

Factory Installed Options (specified in model number at time of STP order)

Designation	Description
F	Floating suction adapter, 1-1/2" NPT female, must be factory installed
K	IFS (intake filter screen), factory assembled to pump motor assembly
R	Model R check valve, factory installed, for Veeder-Root PLLD Line Leak
W	Model W check valve, factory installed, for Red Jacket PPM4000 Line Leak
AG	Alcohol-gasoline compatible

Field Installed Options (fixed speed specific accessories)

Part Number	Description
400137908	Syphon check valve, alcohol-gasoline compatible (when ordered with STP)
400818921	STP-CBS, single-phase control box with lockout switch, 110 Volt coil
402312921	STP-DHI-SCI, combo DHI with factory wired STP-SCI (when purchased with a 4" STP)
402312921	STP-DHI-SCI, combo DHI with factory wired STP-SCI (when purchased without a 4" STP)*
402313921	STP-DHI-CBS, combo DHI with factory wired STP-CBS
402459931	Model 65 psi check valve (for slave of manifolded STPs with Veeder-Root PLLD)
402507930	Secondary syphon kit (when two syphon primes are required for one STP)
5800100215	STP-SCI, single-phase smart controller (when purchased without a 4" STP)
5800100215	STP-SCI, single-phase smart controller (when purchased with a 4" STP)*
5800300100	STP-DHI, dispenser hook isolation for 110 Volt dispenser handle switches, up to eight each

*When purchasing STP-SCI or STP-DHI-SCI in equal quantities of fixed speed 4" STPs, the STP-SCI or STP-DHI-SCI will be invoiced at special discount pricing.